

Order Form

Sandwich Panel Bracket (GST150SPB & GST190SPB)

enquiry order

date _____
 name _____
 company _____
 address _____

Contents of each Sandwich Bracket pack/set:
 10 no. Clamp including glued in EPDM Seal
 10 no. Sandwich Panel Bracket
 41 no. Self-tapping stainless steel screws for Clamp
 21 no. Self-tapping stainless steel screws for Sandwich Panel Bracket

1) Sandwich Panel Brand/Product:

Kingspan KS1000EWs for example

Other: Please give details

For Bespoke: Please fill in → measurements on the illustration

2) Core Thickness:

40-60mm 120-140mm
 80-100mm

3) Size of Gutter

150mm 190mm

4 Quantity (N.B. only sold in multiples of 10)

_____ x 10pcs (Sandwich Panel Bracket incl. clamp & screws)

5 Material & Colour

Plain Galv Colour Coated Galv

Please Specify Colour: _____

from: Sepia Brown, Grey White RAL 9002, Grey Aluminium RAL 9007 or Anthracite Grey RAL 7016

Illustrate for bespoke:

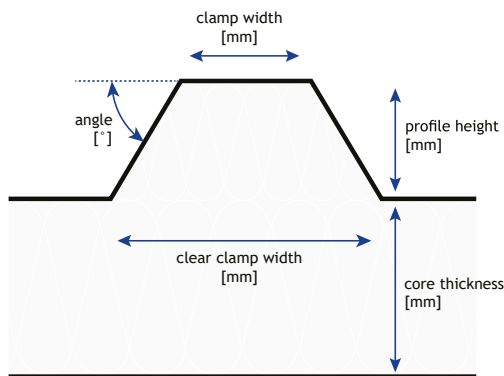

Clamp Width: _____ mm

Profile Height: _____ mm

Clear Clamp Width: _____ mm

Core Thickness: _____ mm

Brand: _____

Type: _____

Angle: _____ °

Optional Extra: Eaves Flashing

For the assembly of Sandwich Panel Brackets

1 Quantity of eaves flashing _____ mtrs

2 Material & Colour:

Zinc Plain Galv
 Colour coated Steel
 RAL 7016 Anthracite Grey

3 Optional Additional Screws

Quantity: _____ x 41 pcs Self-tapping stainless steel A2 Screws

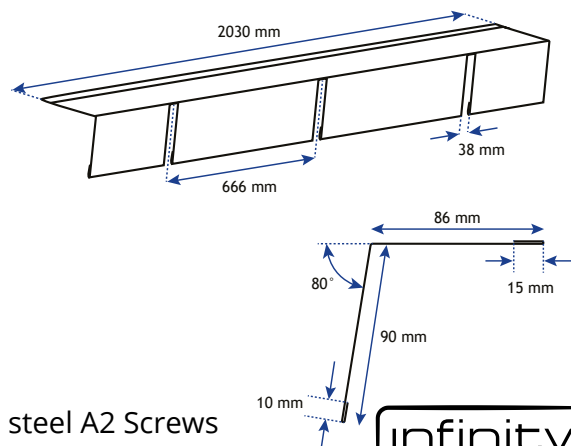

Tel: 0800 644 44 28 • info@infinityguttering.co.uk

Infinity Guttering/Rainclear Systems: Unit 34A, Techno Trading Estate, Ganton Way, Swindon, Wiltshire SN2 8ES

Rainclear Systems is an agent of Alumasc Building Products Ltd. White House Works, Bold Road, St. Helens, WA9 4JG - Company registration number 02992960 - VAT number GB 395 9417 96

The future of roofline